

Rev No.	Description	Date	Name
D	First light	07/06/06	A.Vismara
E	New LED holder	10/05/08	A.Vismara

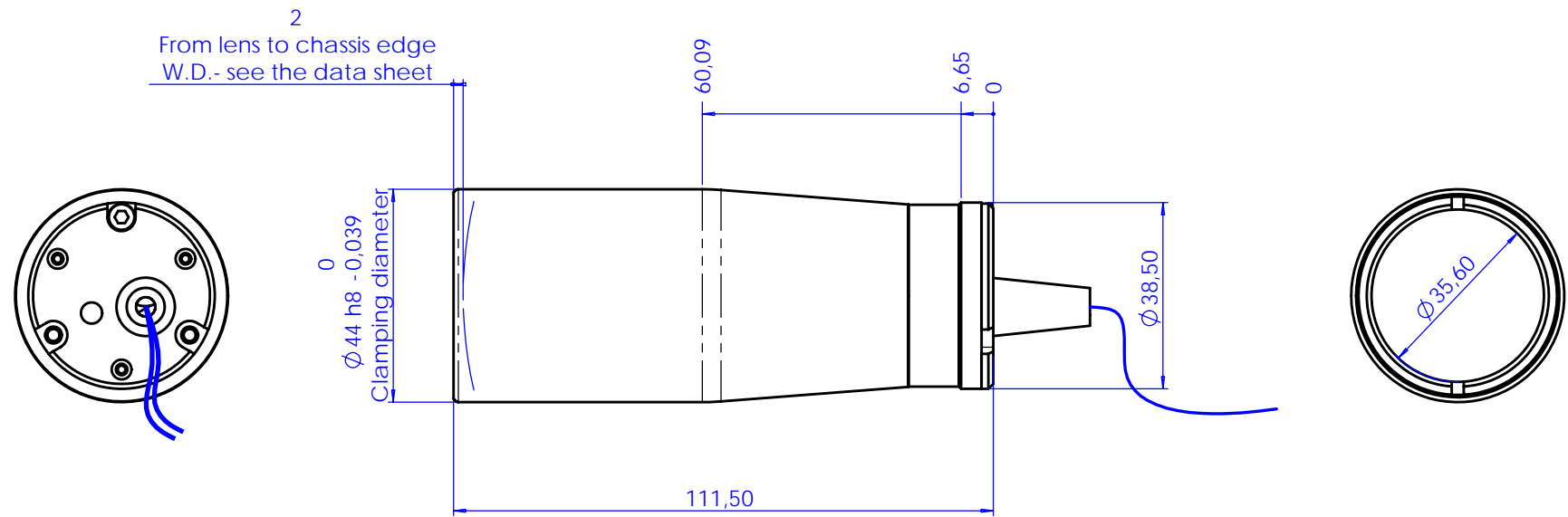

Material	N.A.			Mass	0.30 kg	Scale	1:1
Surface treatment	N.A.			Project-Prod.Item/Instrument		LT CL 24	
Geometrical tolerance (ISO 2768-2)			Class	K	Undimensioned bevels	1x45°	Description
Linear tolerance (ISO 2768-2)			Class	m			
0.5	>3-	>6-	>30-	>120	>400-	>1000	>2000
±0.1	±0.1	±0.2	±0.3	±0.5	±0.8	±1.2	±2
www.opto-engineering.com		Date		Name		Drawing No.	
		Designed	10/05/08	A.Vismara		01277-0-E	
		Draw	10/05/08	A.Vismara		Sheet	
		Checked	X	C. Sedazzari		1/1	
OPTO ENGINEERING S.r.l. - 46100 Mantova Italy - Via Cremona, 29/2 - Tel. +39 0376 263525 - e-mai: info@opto-engineering.com - http://www.opto-engineering.com							